

INSTALLATION INSTRUCTIONS



PRODUCTS, INC.

1917 OAK PARK BLVD. • PLEASANT HILL, CA 94523
(925)935-3025 • Fax (925)935-2287

www.dedenbear.com • email@dedenbear.com

TS-6 Second
Stage Kit
Model TS6SSK

INSTALLATION

- 1) Remove the plug (5/8" bolt) and gasket from the throttle stop using a 15/16" wrench. It is located at the end of the block that has the Dedenbear logo.
- 2) Install the right angle quick disconnect fitting into the back of the brass air cylinder, and thread the locknut about half way down the cylinder's threaded end. Screw the cylinder in to the now open hole in the throttle stop. Do not tighten the locknut now, wait until the initial second stage throttle position has been set.
- 3) Mount the new solenoid to the bottom of the first stage solenoid pack bracket. Use the #8-32 screws and lock washers to fasten the solenoid. Install the supplied quick disconnect fittings and plumb the solenoid per the diagram on page 2. Splice in the supplied air line "Y" between the bottle and the first stage solenoid for a CO2 supply.
- 4) Connect one of the solenoid wires to a good chassis ground (either one, the solenoid is not polarity sensitive), connect the other wire to the output on your **second** throttle stop controller, 18 gauge wire is sufficient. See page 3.
- 5) On early Dedenbear timers the "N.C." terminal is used, on Model TSC-2A & TSC-4 controllers, move the "output" switches up to "ON-OFF-ON" mode, and if a Model SCC-1 or CC-1 microprocessor style unit is used change the throttle stop output to "BASEPLATE STYLE".

From here on these instructions will refer to your first throttle stop controller (responsible for the first stage/fully closed throttle position) "controller A" and your second throttle stop controller (responsible for the second stage/intermediate throttle position) "controller B" and their timers will be referenced as A1 (timer one in controller A) A2 (timer two in controller A) B1 (timer one in controller B) etc..

OPERATION

- 1) The disc stop's intermediate throttle position is adjusted by threading the brass air cylinder either in (clockwise) or out (counter-clockwise). Threading in will increase the intermediate opening size (raising RPM while the second stage is activated) and threading out will decrease the opening size (lowering RPM while the second stage is activated). Make sure to tighten the locknut after adjustments.
- 2) For the initial adjustment of the intermediate throttle position and for insurance that all of the plumbing and wiring have been done correctly it is recommended that the carburetor be removed so the action of the throttle stop can be visually observed.
- 3) Set the intermediate throttle position (about 1/2 way between the closed and wide open position is a good place to start) and lock down the jam nut.
- 4) Choose a throttle stop sequence (the most popular are listed on page 4) and program controllers A & B accordingly.
- 5) Cycle the throttle stop controllers by activating the transbrake and watch the discs carefully as they open and close to ensure that the throttle positions, opening and closing rates, and the sequence of actions (wide open / intermediate / closed / back to intermediate / back to wide open) are correct.
- 6) This is a good time to experiment with needle valve adjustments: open and close the valves while cycling the stop to establish a nice smooth transition between opening and closing throttle positions. In general, the faster you can open and close the stop without spinning the tires, the more consistent the car will run.
- 7) This is also the ideal time to experiment with changing controller A & B timers. Try changing on times, times between stages (wide open, intermediate, and closed). Try changing the overall duration of the stop. This can get a little confusing, but by watching how the discs respond to timer changes before the carb goes back on and you can no longer see them, you will get a much better understanding of what is changing.
- 8) Once you feel the stop is set up correctly, bolt the carb back on & go racing.

LIMITED 1 YEAR WARRANTY

Dedenbear Products components are warranted directly by Dedenbear Products against defective materials or workmanship under normal use and service for a period of one (1) year after purchase. Dedenbear Products will repair or replace the defective unit, at Dedenbear Products option, free of charge. This warranty does not cover any damage to the component caused by abuse, mishandling, alteration, accident, electrical current fluctuations, failure to follow installation/operating instructions, maintenance, storage and environmental conditions, acts of God, or repair attempts made by anyone other than Dedenbear Products Authorized Service facility. DEDENBEAR PRODUCTS SHALL NOT BE LIABLE FOR INJURY, CONSEQUENTIAL, OR OTHER TYPE DAMAGES RESULTING FROM THE USE OF ITS PRODUCTS, OTHER THAN THE LIABILITY STATED ABOVE. This warranty is in lieu of all other warranties of merchantability or fitness of use. This warranty gives you specific legal rights, and you may also have other rights which vary from state to state.

FOR SERVICE on all Dedenbear Products, return directly to: DEDENBEAR PRODUCTS, INC. • ATTN: REPAIRS • 1917 OAK PARK BLVD. • PLEASANT HILL, CA 94523. Please include a note describing the nature of the problem, a copy of your original invoice, your name, return shipping address, and daytime & evening phone numbers where you can be reached.

AIR SOLENOID

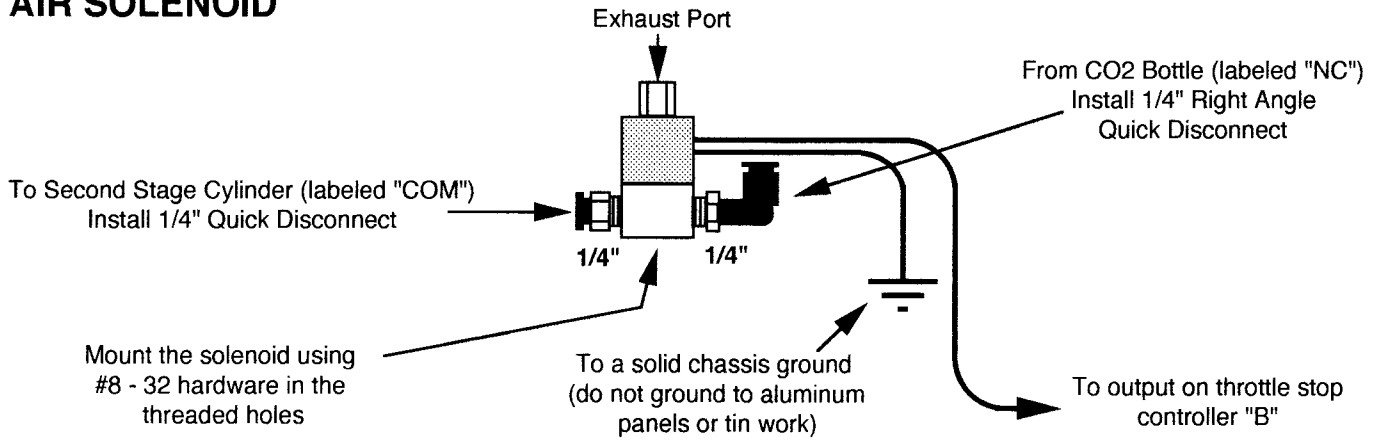

AIR LINE PLUMBING

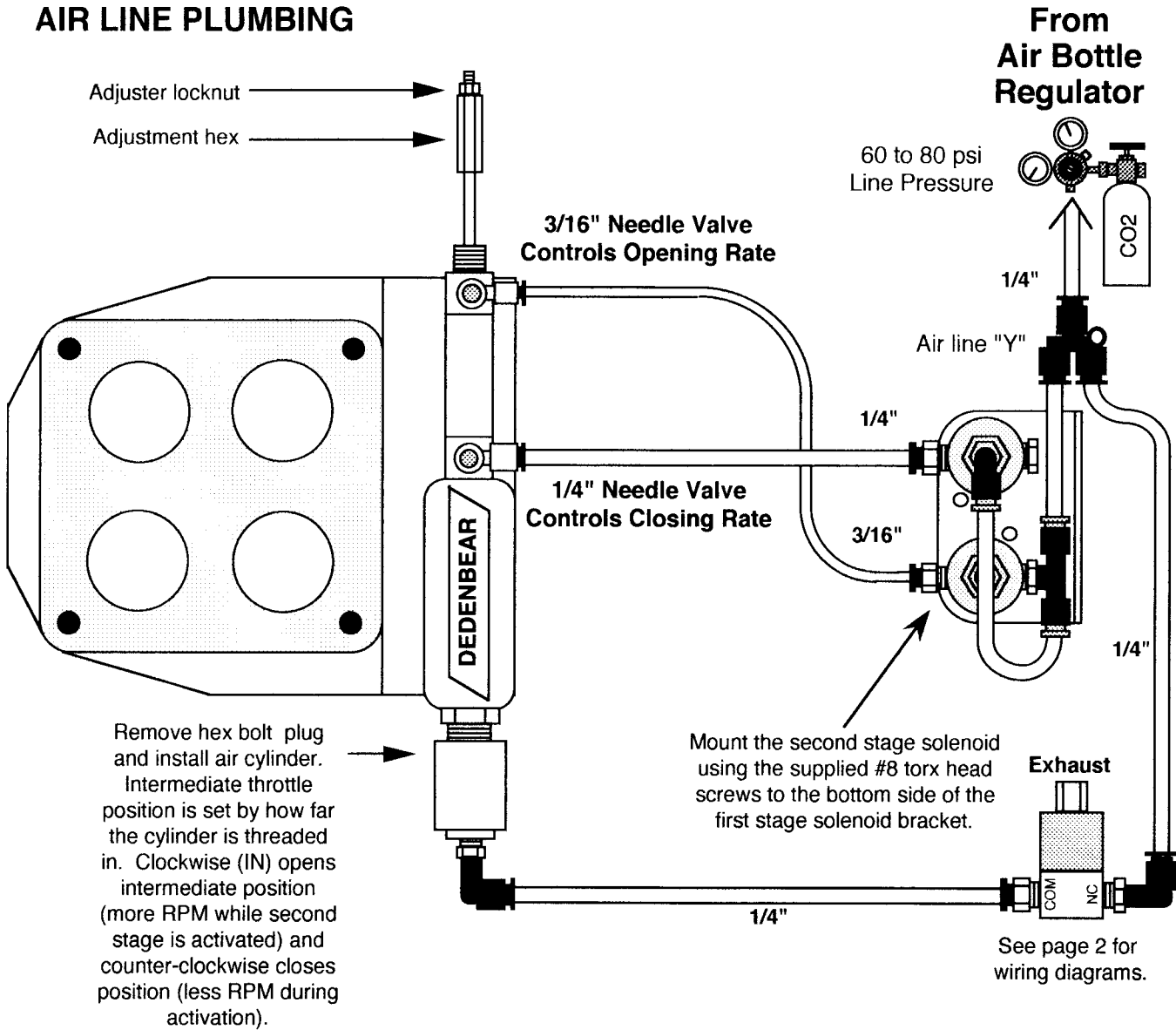

WIRING WITH COMMAND CENTER

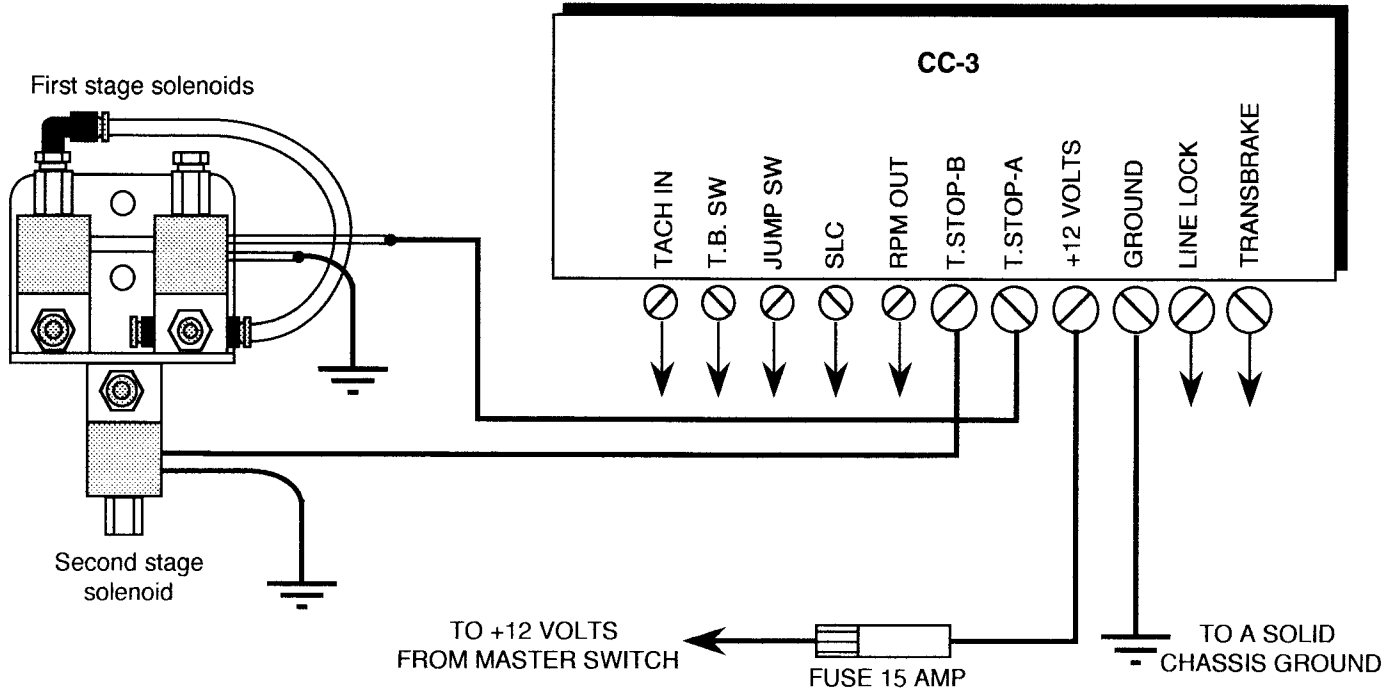

NOTE: SET T.STOP "A" FOR "LINKAGE STYLE" AND T.STOP "B" FOR "BASEPLATE STYLE"

WIRING WITH 2 SEPARATE CONTROLLERS

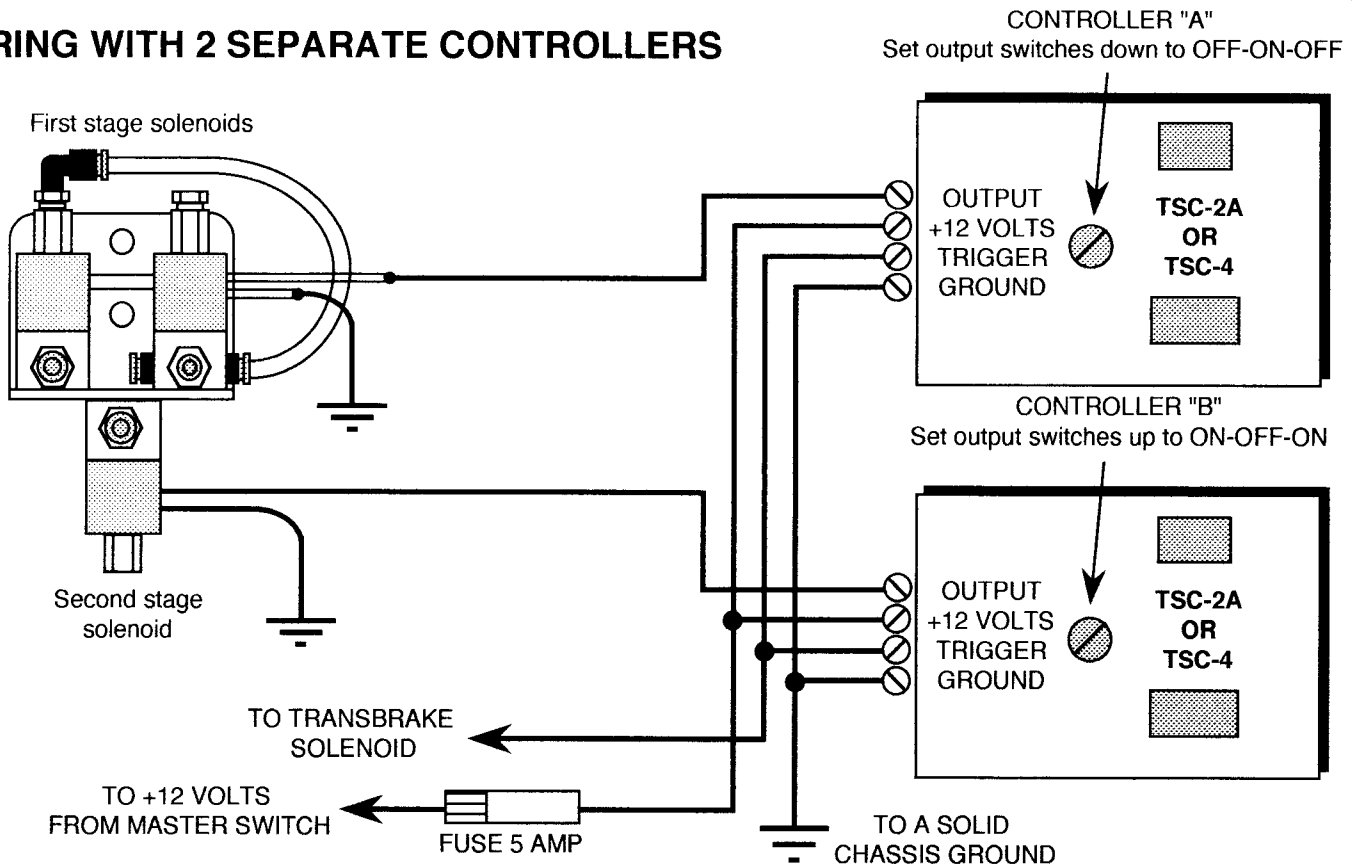

NOTE: THERE ARE SEVERAL OTHER WIRING OPTIONS FOR DIFFERENT TIMERS AND CONFIGURATIONS, IF YOU NEED A DIFFERENT DIAGRAM, CALL DEDENBEAR AT (925) 935-3025. TS6SSK 3of4 Rev. 07/03

OPERATION SCENARIO ONE

Scenario one is the most common way of setting up a dual stage throttle stop, opening and closing the stop progressively in both directions. The car launches wide open, drops to the intermediate throttle position, then to the closed position. After the needed timer duration (typically 1.5 to 2.5 sec. depending on how far the car runs under the index) the stop transitions from the closed, back to the intermediate, then back to the wide open throttle position. This allows for a smooth transition both closing (to prevent chassis unloading) and opening (to prevent tire spin). To accomplish this operation, Timer A1 is time from wide open launch to intermediate change, B1 is time from launch to fully closed change, B2 time changes from closed back to intermediate, and A2 time changes from intermediate back to wide open. See schematic below.

In this scenario E.T. changes are made by changing timer A2 only; adding time to slow E.T. and subtracting to add to E.T.

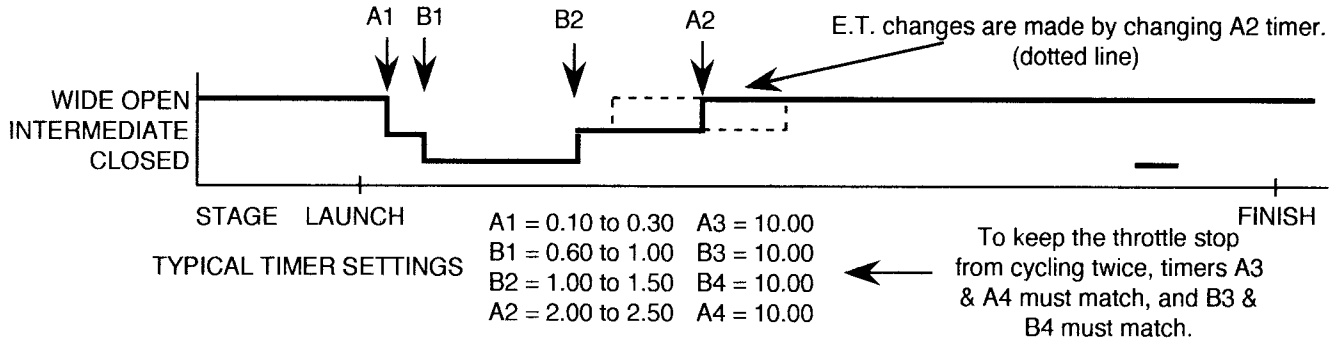

OPERATION SCENARIO TWO

Scenario two is similar to one, but progressively closes and opens the stop not once but twice. Try this once you have mastered scenario one, as it becomes very complicated very quickly, but when done properly can add a new advantage to your program by allowing you to fake a "dump" near the end of the pass by cycling the stop again and having your car drop off several MPH just before the traps.

E.T. changes are made the same as scenario one, by changing timer A2 only.

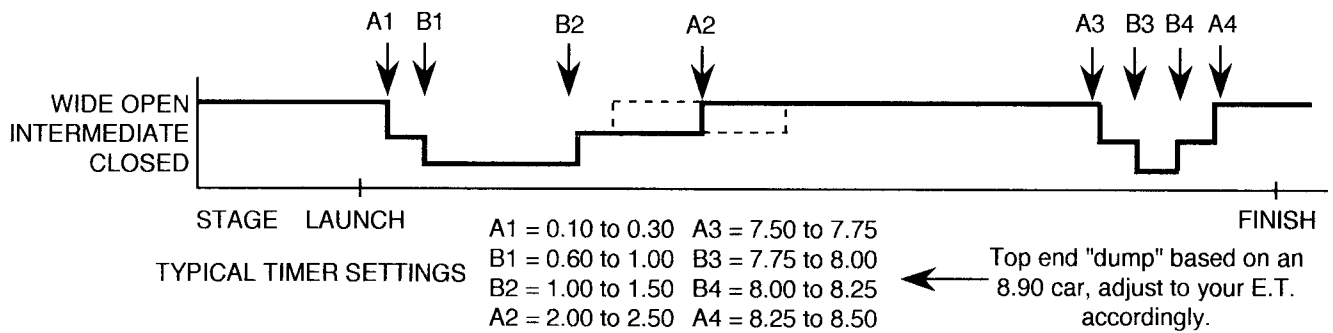

OPERATION SCENARIO THREE

Scenario three simply demonstrates a different approach to adjusting the timing of the stop to change your E.T. by choosing a "split time" between the intermediate and wide open positions on the opening, and changing both timer B2 and A2 together to change the duration. For example, with a 0.5 split time, if B2 was set at 2.00 sec. A2 would be set at 2.50 sec. If you needed to slow the car down by adding to the stop's duration, you would add the same time to both timers maintaining the split time, i.e. B2 from 2.00 to 2.25 and A2 from 2.50 to 2.75.

This scenario also demonstrates how to adjust the timers so the stop closes nonprogressively (no intermediate position) so the car comes down off the line "hard". This allows the car to slow down quicker, potentially shortening the amount of time the stop needs to be on to obtain the desired E.T.

Either one of these practices may be applied to the scenarios 1 & 2. Be creative, the potential options for the disc stop are unlimited.

By setting both A1 & B1 for the same time (i.e. A1=0.20, B1=0.20) the discs will go from wide open directly to fully closed bypassing the intermediate stage.

