

CONVERSION INSTRUCTIONS



1917 OAK PARK BLVD. PLEASANT HILL, CA 94523
(925)935-3025 FAX (925)935-2287
www.dedenbear.com email@dedenbear.com

Model AS1C Conversion from Forward Pattern to Reverse Pattern

The model AS1C is designed to allow racers to convert their existing Dedenbear AS4 to the AS1 shifter using the existing solenoid valve and cylinder. Since your new transmission will have a different pattern for the gears, be sure you have a block off plate replacement and gate plate with your new shift pattern for the Turbo Action Cheetah SCS shifter. If not, it is available from Dedenbear: Part no. SGGM3R (Chevy), SGFORD3R (Ford), SGCHRY3R (Chrysler).

Once the conversion is done, the original AS1 installation instructions (included) will show you how to install the new bracket assembly onto your Turbo Action shifter.

CONVERSION

- 1) Remove the AS4 air shifter from the front of the Turbo Action shifter. Keep the four 1/4-inch bolts. These bolts will be needed later to attach the new AS1 bracket to the shifter. Reinstall the original Turbo Action front feet in this location.
- 2) Remove the air lines from the AS4 by pushing in on the fitting lock rings while pulling on the tubing. Remove the solenoid and brass cylinder from the bracket.
- 3) Remove the collar from the end of the cylinder plunger, you will no longer need this. Install the valve and cylinder onto the new AS1 bracket as shown below. If you wish, you can replace the short hose assembly with the replacement tube provided. Do not cut the tubing, it has already been cut to length.
- 4) Remove the Dedenbear neutral safety switch assembly from the back of the Turbo Action shifter. This whole unit should be replaced by the original Turbo Action neutral safety switch assembly supplied by Turbo Action when you first purchased your shifter. If you no longer have that piece, order part no. #70212 from Turbo Action.
- 5) Use the included AS1 installation instructions to install the AS1 to your shifter.

ASSEMBLY DIAGRAM

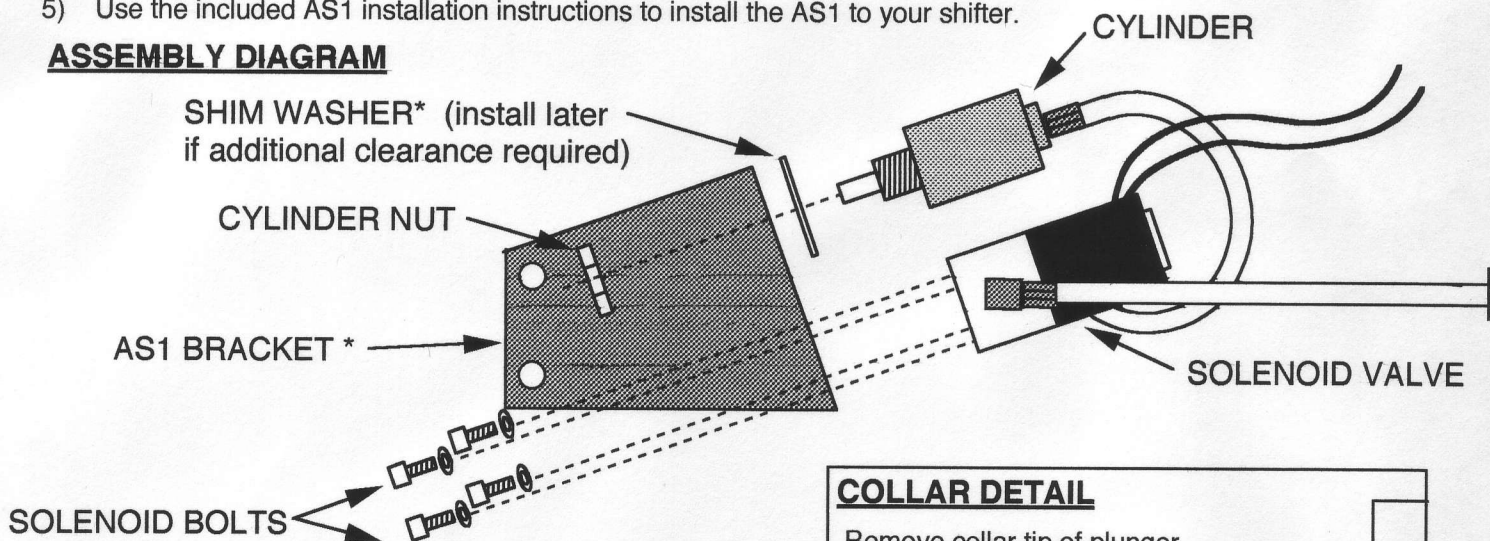

* Denotes new parts that are included in this conversion kit. Other parts shown are from the original AS4 shifter assembly and are to be re-used.

COLLAR DETAIL

Remove collar tip of plunger

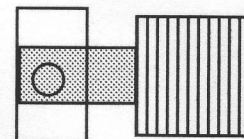

This collar will not be used in the AS1 application.