

INSTALLATION INSTRUCTIONS



1917 Oak Park Blvd. • Pleasant Hill, CA 94523
(925)935-3025 • Fax (925)935-2287
www.dedenbear.com • email@dedenbear.com

Model PGP-IK INSTALLATION KIT FOR POWERGLIDE PUMP

This installation kit was designed for easy installation of the Dedenbear PGP-1 Powerglide racing oil pump. It contains: 1) pump gasket, 1) pump seal, 7) bolt seals, 1) roller thrust bearing, 2) teflon high gear sealing rings, 1) each of .010", .018", .025" shims.

Below is a copy of the installation procedure from the PGP1 instructions

Installation into transmission with Dedenbear Installation Kit

1) Discard the factory bronze high gear drum thrust washer. Find the .010 thick adjustment shim (determine this by measuring the shim thicknesses) and slide it over the hub of the pump. Next, slide the roller thrust bearing over the hub with the large flange closest to the pump as shown in the drawing.

2) Install the two new teflon high gear drum seal rings onto the hub and install the square o-ring onto the outside of the pump body. Lubricate the o-ring with ATF or assembly lubricant. Pour some ATF into the pump ports to pre-lube the gears.

3) With the transmission standing upright, install the oil pump to transmission case gasket and lower the pump into the case. Put the sealing washers on the pump to case bolts and lube the bolt threads. Install the bolts and torque them to 13 - 17 ft-lbs.

4) Insert the input shaft. Set up a dial indicator on the end of the shaft. Lift up on the output shaft and read the amount of endplay on the dial indicator. The desired amount is .005 - .015 inches.

5) If the endplay is within tolerances, you are done. If not, determine how much the endplay needs to be changed, then remove the pump from the case.

6) Remove the roller thrust bearing and shim. Select the proper shim from the kit or use multiple shims to make the necessary change in the endplay amount and slide them over the hub. Re-install the roller thrust bearing.

7) Repeat steps 3 thru 5 until the correct endplay is achieved.

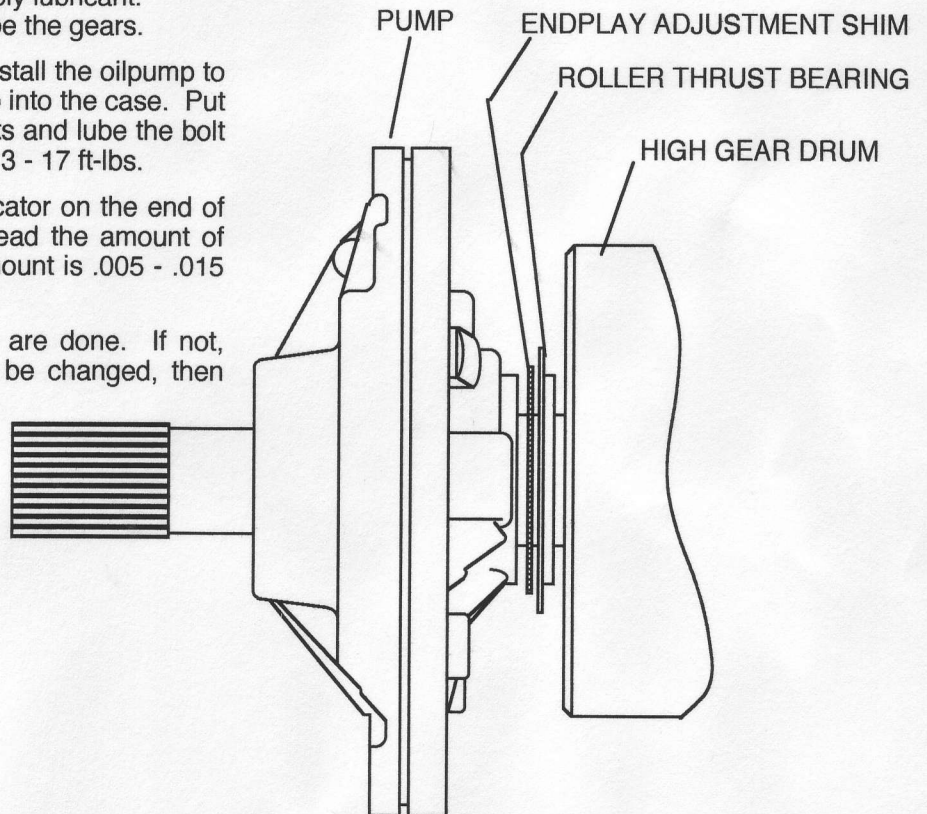

WARNING:

DO NOT MODIFY THIS OIL PUMP IN ANY WAY! IT HAS UNDERGONE HUNDREDS OF HOURS OF DESIGN, DYNO TESTING, AND ON-TRACK EVALUATION. THIS IS AN ENGINEERED PART THAT HAS BEEN OPTIMIZED FOR MAXIMUM COOLANT FLOW, CONVERTER CHARGING, OPERATING PRESSURE AND OIL FLOW. MODIFICATIONS WILL DEGRADE IT'S PERFORMANCE, VOID THE WARRANTY, AND POSSIBLY CAUSE ENGINE & TRANSMISSION DAMAGE DUE TO EXCESSIVE CONVERTER PRESSURE.

CUSTOMER SERVICE & TECH. SUPPORT : (925)935-3025 Mon-Fri 8am-5pm PST