

MULTIPLE RELAY CENTER INSTALLATION & OPERATION MANUAL

INDEX

Installation Instructions.....	pg 1	Wiring options for relay # 5.....	pg 3
Wiring for Fan, Fuel Pump, etc.....	pg 2	Troubleshooting & Warranty.....	pg 4

INSTALLATION

Using #8 screws through the rubber grommets in the base, mount the MRC-1 away from heat and vibration. Wire as shown in the following diagrams using quality automotive wire. Make sure to use a solid chassis point for all grounds. Sheet metal and tin work grounds are not reliable.

OPERATION

Relays are used to handle the load of a high current draw component. When a relay is triggered, the contacts move, connecting or disconnecting the component. To trigger a relay, power must be supplied to one side of the relay's coil and ground to the other side.

The MRC-1 was designed to simplify the installation of multiple relays in a race car. Relays #1, 2, 3 & 4 are all normally open (NO) and have the commons (COM) tied together and one side of the coil tied together. They can be used to supply power or ground to components and can be triggered with either power or ground, but all four relays must be triggered the same and all four outputs must be the same. Relay # 5 is completely isolated and can be used normally open (NO) or normally closed (NC). It can also supply power or ground and be triggered with power or ground but because it is isolated it can be wired to perform differently than relays # 1 through 4.

Most of the wiring diagrams in these instructions show the relays wired for a positive trigger and positive output. This is the most common way to wire a relay and especially in nitrous applications, the safest. If you wish to wire your MRC-1 with either a negative trigger, negative output, or both, call Deddenbear for a custom diagram.

FUSES

All 5 relays are individually protected by 20 amp fuses. Choose a fuse of appropriate size for each output depending on the current draw of the component. Pick a fuse rated about 5 amps greater than the draw, for example if your fuel pump draws 20 amps, use a 25 amp fuse, if your nitrous solenoids draw 10 amps, use a 15 amp fuse. Each output is rated at a maximum of 30 amps.

INDICATOR LED'S

There are a series of trouble shooting LED's on the face of the MRC-1. Each green light indicates the coil of a relay, each red light indicates the output of a relay (relay #5 has no output LED due to it's NO & NC capabilities).

When a relay is triggered the green LED will illuminate. When the relay outputs, the red LED will illuminate. Use the troubleshooting chart below to help find problems.

WIRING RELAYS # 1 TO # 4

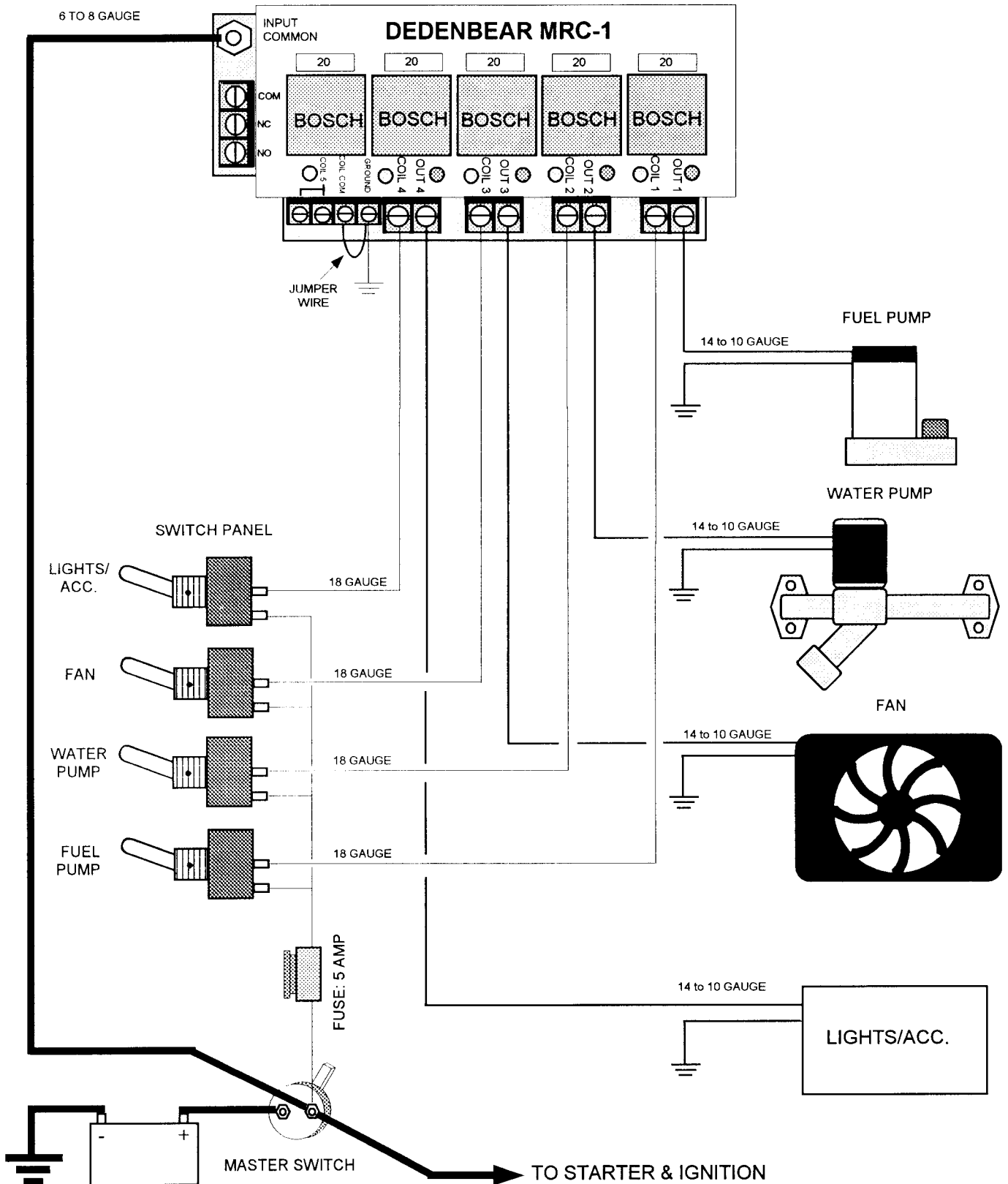

RELAY # 5 WIRING OPTIONS

Wiring for push style electric shifter with Dedenbear RPM switch or Command Center

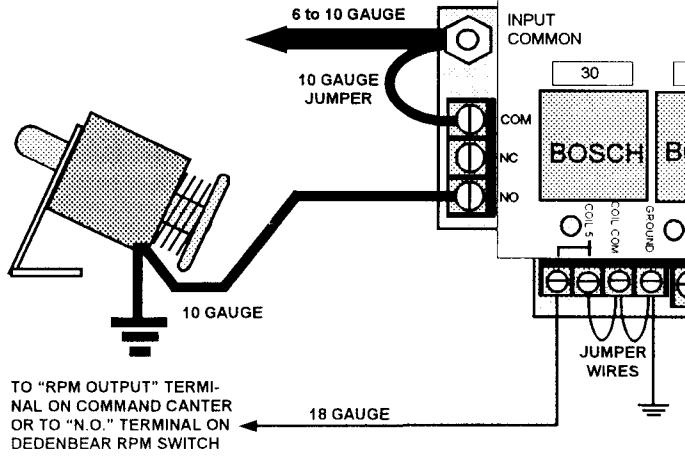

Wiring for push style electric shifter with MSD 8950 or MSD 7AL3 RPM switch

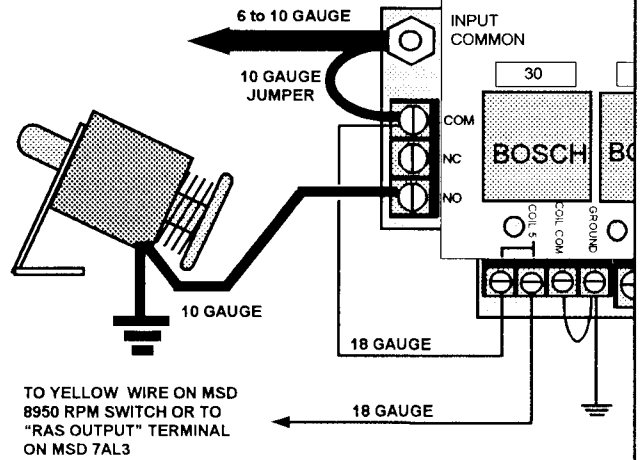

Wiring for hold style electric shifter with MSD 7AL3 RPM activated switch

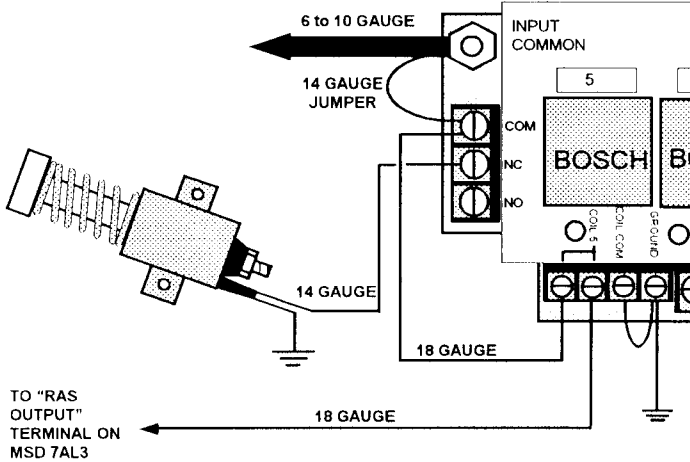

Wiring for single stage nitrous staging relay (keeps nitrous off until transbrake release)

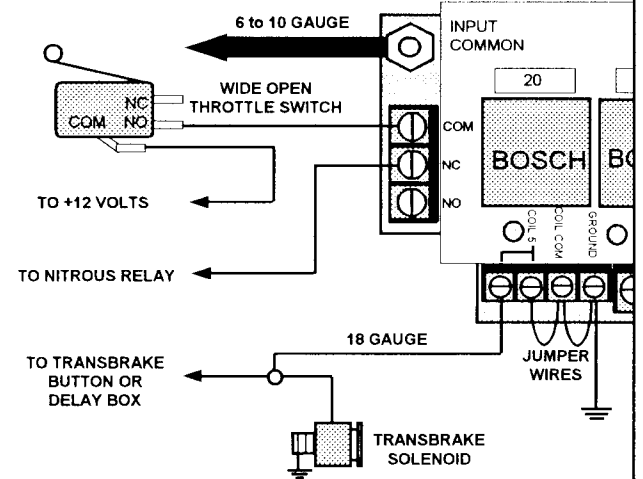

Wiring for positive MSD retard activation of MSD 7AL3 or MSD multi-step retard

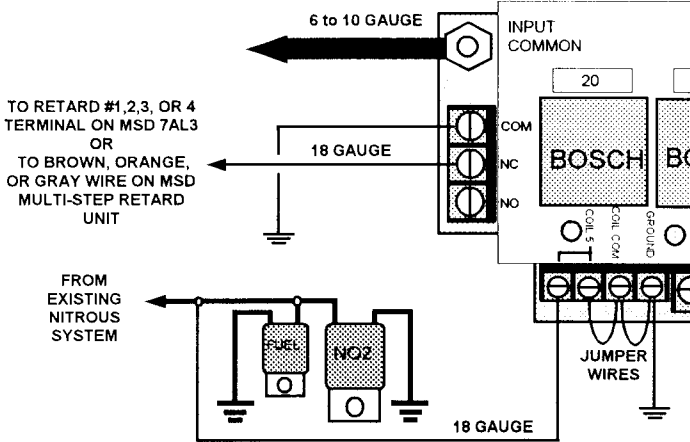

Wiring to function the same as relays #1 to #4

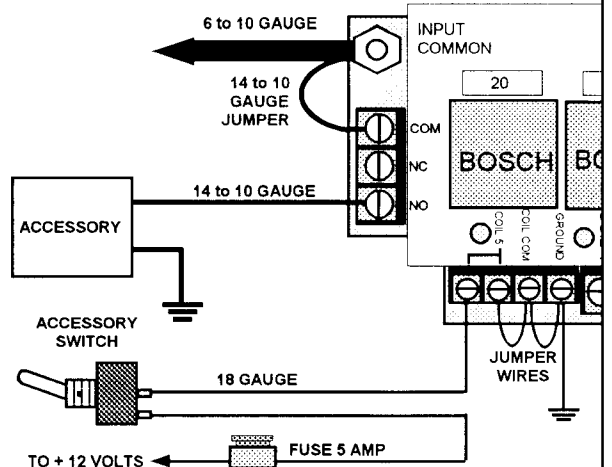

TROUBLESHOOTING

Indication	Possible causes
Green coil light will not turn on	Problem is "before" the MRC-1. The power or ground (whichever you are using to trigger) is not making it to the affected coil terminal. The coil common is not properly grounded (for power triggered coils) or is not properly powered (for ground triggered coils).
Green coil light turns on, but red output light will not turn on	Problem is "in" the MRC-1. The input common is not properly powered (for positive output) or grounded (for negative output). The fuse is blown due to a short circuit on the output. The relay is defective.
Green coil light and red output light turn on but the accessory does not turn on	Problem is "after" the MRC-1. The wiring between the MRC-1 and accessory is defective. The accessory itself is defective. The accessory is not properly grounded.

SERVICE AND WARRANTY

SERVICE

DO NOT RETURN TO DISTRIBUTOR, CALL DEDENBEAR DIRECTLY.

If you think your box has a problem or needs to be serviced, call us first before removing it from the car (we may be able to troubleshoot the unit while it is still in the car). If it is necessary to return the unit to our facility, call first; then package it carefully and include a note describing the problem. Provide your name, address, work and home phone numbers so we can contact you regarding return shipment. Turn-around time on repairs is typically 24-48 hours.

CALL DEDENBEAR, MONDAY TO FRIDAY, 8 AM TO 5 PM PACIFIC TIME
SHIP TO: DEDENBEAR PRODUCTS, REPAIR DEPARTMENT, 1917 OAK PARK BLVD., PLEASANT HILL CA 94523

LIMITED 1 YEAR WARRANTY

Dedenbear Products components are warranted directly by Dedenbear Products against defective material or workmanship under normal use and service for a period of one (1) year after purchase. Dedenbear Products will repair or replace the defective unit at Dedenbear Products option, free of charge. This warranty does not cover any damage to the component caused by abuse, mishandling, alteration, accident, electrical current or voltage fluctuations, failure to follow installation/operating instructions, storage and environmental conditions, or repair attempts made by anyone other than Dedenbear Products authorized service facility.

DEDENBEAR PRODUCTS SHALL NOT BE LIABLE FOR INJURY, CONSEQUENTIAL, OR OTHER TYPE DAMAGES RESULTING FROM THE USE OF ITS PRODUCTS, OTHER THAN THE LIABILITY STATED ABOVE. This warranty is in lieu of all other warranties of merchantability or fitness of use. This warranty gives you specific legal rights, and you may also have other rights which vary state to state.

1917 Oak Park Blvd - Pleasant Hill, CA 94523 - (925) 935-3025 - Fax (925) 935-2287 - www.dedenbear.com - email@dedenbear.com